

Analog Peripherals

10-Bit ADC

- ± 1 LSB INL; no missing codes
- Programmable throughput up to 100 ksps
- 8 external inputs; programmable as single-ended or differential
- Programmable amplifier gain: 16, 8, 4, 2, 1, 0.5
- Data-dependent windowed interrupt generator
- Built-in temperature sensor (± 3 °C)

8-Bit ADC

- ± 1 LSB INL; no missing codes
- Programmable throughput up to 500 ksps
- 8 external inputs
- Programmable amplifier gain: 4, 2, 1, 0.5

Two 12-Bit DACs

- Can synchronize outputs to timers for jitter-free waveform generation

Two Comparators

Internal Voltage Reference

V_{DD} Monitor/Brown-out Detector

On-Chip JTAG Debug & Boundary Scan

- On-chip debug circuitry facilitates full speed, non-intrusive in-system debug (no emulator required)
- Provides breakpoints, single stepping, watchpoints, stack monitor
- Inspect/modify memory and registers
- Superior performance to emulation systems using ICE-chips, target pods, and sockets
- IEEE1149.1 compliant boundary scan

High-Speed 8051 μ C Core

- Pipelined instruction architecture; executes 70% of instructions in 1 or 2 system clocks
- Up to 25 MIPS throughput with 25 MHz system clock
- 22 vectored interrupt sources

Memory

- 4352 bytes data RAM
- 64 kB Flash; in-system programmable in 512-byte sectors (512 bytes are reserved)
- External parallel data memory interface

Digital Peripherals

- 64 port I/O; all are 5 V tolerant
- Hardware SMBus™ (I2C™ compatible), SPI™, and two UART serial ports available concurrently
- Programmable 16-bit counter/timer array with 5 capture/compare modules
- 5 general-purpose 16-bit counter/timers
- Dedicated watchdog timer; bidirectional reset
- Real-time clock mode using Timer 3 or PCA

Clock Sources

- Internal programmable oscillator: 2–16 MHz
- External oscillator: Crystal, RC, C, or Clock
- Can switch between clock sources on-the-fly

Supply Voltage: 2.7 to 3.6 V

- Typical operating current: 10 mA at 25 MHz
- Multiple power saving sleep and shutdown modes

100-Pin TQFP

Temperature Range: -40 to $+85$ °C

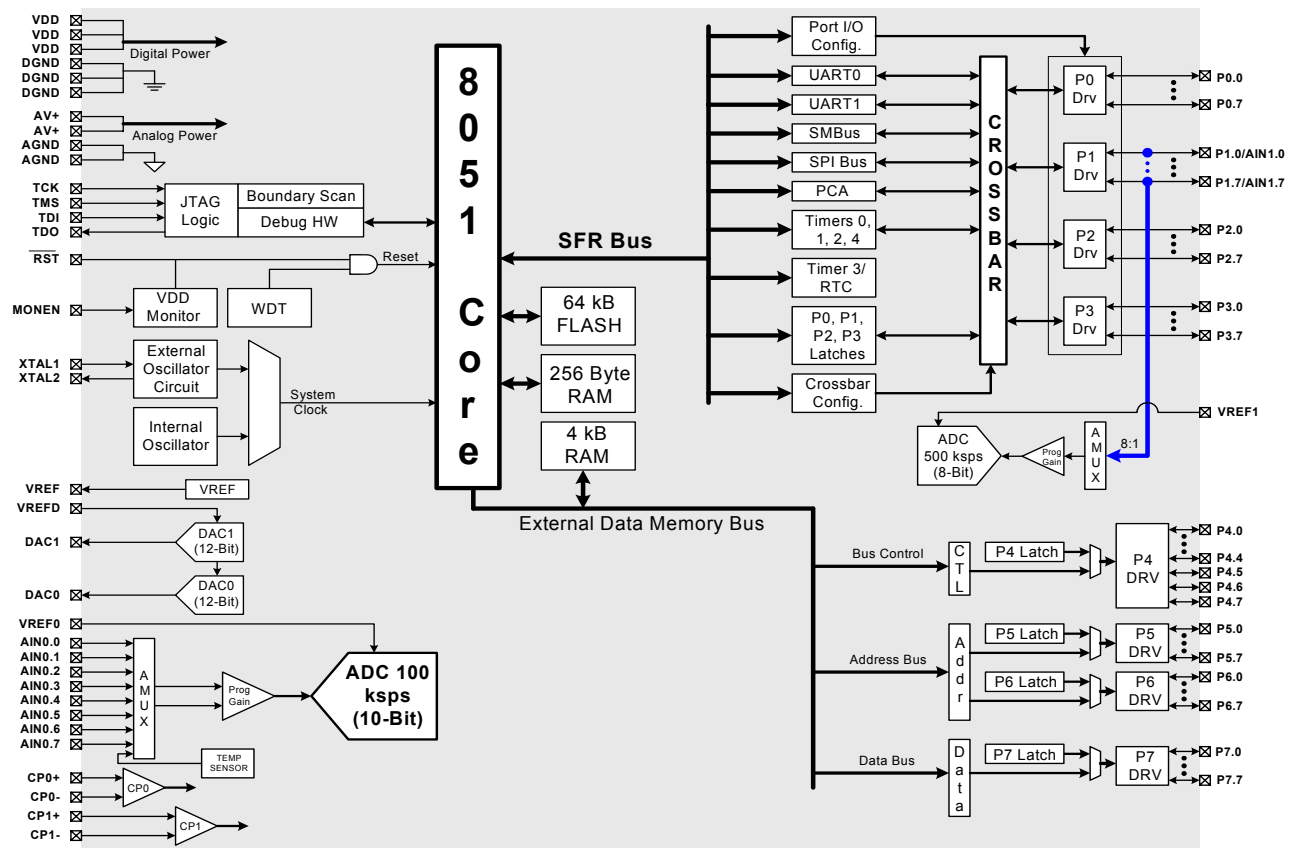

Selected Electrical Specifications

($T_A = -40$ to $+85$ °C, $V_{DD} = 2.7$ V unless otherwise specified)

PARAMETER	CONDITIONS	MIN	TYP	MAX	UNITS
GLOBAL CHARACTERISTICS					
Digital Supply Voltage		2.7		3.6	V
Digital Supply Current with CPU active ($V_{DD} = 2.7$ V)	Clock = 25 MHz		10		mA
	Clock = 1 MHz		0.8		mA
	Clock = 32 kHz; V_{DD} Monitor Disabled		20		μ A
Digital Supply Current (shutdown)	Oscillator not running; V_{DD} Monitor Enabled		10		μ A
	Oscillator not running; V_{DD} Monitor Disabled		0.1		μ A
Digital Supply RAM Data Retention Voltage			1.5		V
CPU & DIGITAL I/O PORTS					
Clock Frequency Range		DC		25	MHz
Port Output High Voltage	$I_{OH} = -3$ mA, Port I/O push-pull	$V_{DD} - 0.7$			V
Port Output Low Voltage	$I_{OL} = 8.5$ mA			0.6	V
Input High Voltage		$0.7 \times V_{DD}$			V
Input Low Voltage				$0.3 \times V_{DD}$	V
A/D CONVERTER					
Resolution			10		bits
Integral Nonlinearity				± 1	LSB
Differential Nonlinearity	Guaranteed Monotonic			± 1	LSB
Signal-to-Noise Plus Distortion		59			dB
Throughput Rate				100	ksp/s
Input Voltage Range		0		V_{REF}	V
COMPARATORS					
Response Time	$ (CP+) - (CP-) = 100$ mV		4		μ s
Input Voltage Range		-0.25		$V_{DD} + 0.25$	V
Input Bias Current		-5	0.001	+5	nA
Input Offset Voltage		-10		+10	mV

Package Information

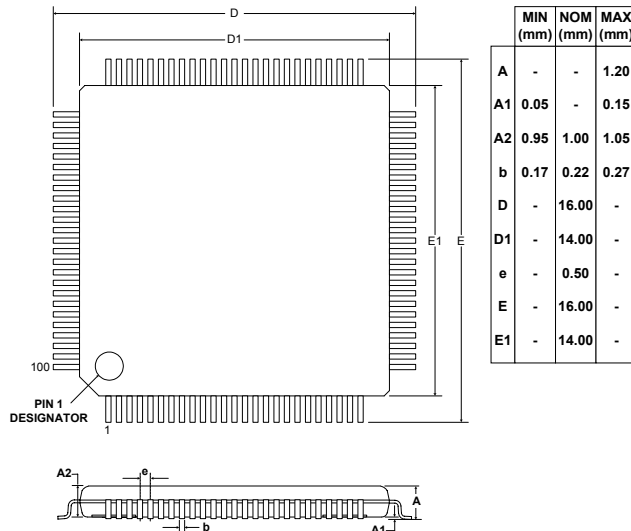

C8051F020DK Development Kit

